

**LEDSTR120 / LEDSTR180**

**LEDSTR120 & LEDSTR180 Solar LED Road Studs**

Designed as an exact alternative to standard road studs. The compatible footprint means they are easily installed as replacements. The surface is smooth and the stud protrudes only 2mm above the ground, reducing the risk of a trip hazard for pedestrians.

The LEDSTR120 and LEDSTR180 offer 4-way LED lighting plus a surface LED, visible from all angles. A full charge will give light for more than 5 days meaning inclement weather won't hinder the performance of these lights.

Photocell controlled, these units will come on when ambient light levels are low and will turn off when ambient light levels are high.

**FEATURES**

- 360° visibility even in bad weather conditions
- Protrudes only 2mm above the ground, offering a slim profile that resists damage from roadworks
- Robust die cast aluminium and polycarbonate construction is highly corrosion resistant and durable
- Reinforced body case fixed by both an anchor and epoxy resin
- Powered by environmentally-friendly solar energy
- No CO<sub>2</sub> emissions
- Waterproof
- No cable laying work or regular maintenance required
- No energy consumption costs
- Long lifespan
- Cost-effective over its lifespan
- Lower maintenance costs than standard road studs
- Suitable for pedestrian crossings, bridges, airports, and any location where extra attention from the public is required



**SPECIFICATIONS**

PRODUCT CODE	LEDSTR120	LEDSTR180
Size	Ø 126mm (Ø 120mm) x H 45mm	Ø 180mm x H 45mm
Weight	650g	1.5kg
Material	Aluminium die casting, Poly carbonate lens	Aluminium die casting, Poly carbonate lens
Viewing Distance	Over 100m	Over 200m
Load	Over 30 tonnes	Over 30 tonnes
Solar Cell	0.45W	1.1W
Battery	LiFePO4 (1,000mAh)	LiFePO4 (1,000mAh)
Operating Temperature	-20°C ~ +65°C	-20°C ~ +65°C
Illumination (lux)	Green Standards (150 lux)	Green Standards (300 Lux)
Operating Time	Over 5 days (fully charged)	Over 5 days (fully charged)
Waterproof Rating (IP)	IPX8	IPX8
Colour	Red, Green, Blue, Yellow, White	Red, Green, Blue, Yellow, White

20 Neilpark Drive  
East Tamaki  
Auckland.  
NEW ZEALAND  
**phone: 64 9 272 5619**

**DIMENSIONS**

**LEDSTR120**

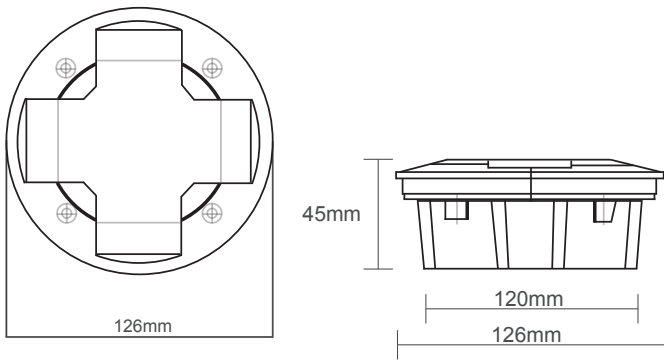

**LEDSTR180**

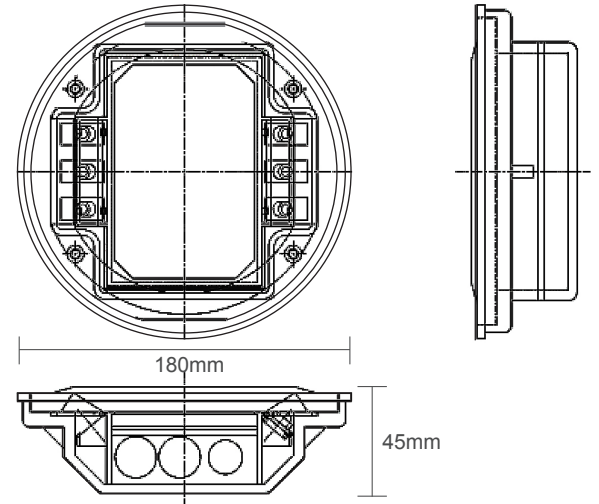

**AVAILABLE COLOURS**

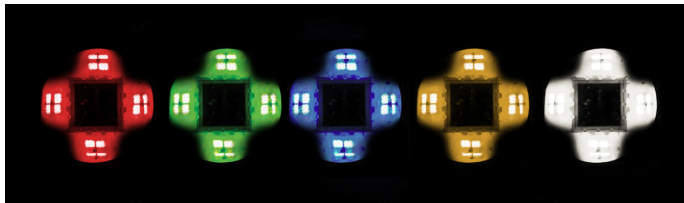

When ordering add suffix to determine colour:

- RD = Red
- GN = Green
- BL = Blue
- YL = Yellow
- WH = White

**PRODUCT IMAGES**

